



CS_α drafts new standards for safety & features to crane scales. It is the perfect solution for safe, speedy, data, flexible and easy connectivity, and managerial reports / data of crane weighing applications.

Thanks to the built-in 24 bit Low-Noise Delta to Sigma ($\Delta-\Sigma$) AD converter, high speed micro-processor, unsurpassed innovative program, new linearity calculating method, wide range of flexible and selectable operation parameters, **CS_α** always deliver affordable & unexceptional fast, accurate and stable results to your crane weighing requirements.

Functions

- Crane Weighing, Peak Hold, Animal function
- Manual, Auto, Continuous and Repetitive Tare
- Powerful Android and iOS Apps available
- Apps Support both Bluetooth and WIFI Connection
- Capacity Tracking Bar to Show Applied & Remaining Capacity
- Multiple Units: - kg, lb and Newton
- Equipped with Second Battery to Provide Continuous Operation
- Fast Plug and Unplug Battery Changing Method, no Tools Required
- Battery Recharging can be done through Scale or Externally
- Supports also Numeric Calibration

Operation Features & Management Data

- Testified Ultimate Overload = 500%
- IR Remote Controller
- Simple and User-Friendly Operation
- Configurable Machine ID, Group Number & Operator Number
- Customer Name and Product Code in English and/or Numeric
- Memory Accumulation & Statics Data Output
- Automatic, Manual, and Q&A Data Output
- Accept Key, Operation Result Inquiry and System Parameter Setting Command through PC
- All Current Operation Results Output in Data Base Format Increases Ease & Efficiency of Data Management, Processing & Analysis
- Support both Ticket Printer and Label Printer
- Label Printers Supported:
 - Datecs: LP-50
 - TSC: TDP/TTP-225, TDP/TTP-247, TDP/TTP-345, DH/TH220 Series, DH/TH240 Series, DH/TH340 Series
- 5 x Selectable Portrait / Landscape Ticket Printout Format
- Configurable Custom Printout Format
- Real Time Clock
- Supervisor Password to Prevent Illegal Access to the WIFI and Bluetooth Module Settings



Versatility, Functionality and Accuracy are always Built-in

CS_a Advanced Wireless Crane Scale

Connectivity

- 2 x Independent Configurable Wireless Communication Ports: -
 - Comport 1 = TTL Output or Bluetooth 2.0 or Bluetooth 4.0 (Standard)
 - Comport 2 = WIFI (Optional)
- 9 x Baud Rate (1200 ~ 256000)
- 10 x Selectable Fixed plus 1 x User Programmable PC Output Protocols
- 10 x Data Transmission Time Interval

WIFI Module (Optional) Supports: -

- Both aCrane Android App & iCrane iOS App
- Access Point (AP) only, Station (STA) only & AP+STA Working Mode

Apps for Smart Phones & Devices

iOS App (iCrane) & Android App (aCrane) are available for free download at App Store and Google Play respectively. Both Apps support connection via Bluetooth and WIFI.

These Apps are so powerful that actually they turn your smart devices into a handheld terminal, remote display, remote data input center and controller of your FM product connected.

User Configurable Parameters

- 6 x Auto Power Off Time
- 5 x Display Brightness
- 3 x Filter Strength
- 6 x Auto Power Off Time
- 3 x Filter Intensity Mode
- Keypad Lock Function
- Configurable Number of Print Copy (1~8)

Smart IR Remote Controller

- 10-Keys Design Provides One Touch Operation to All Operation Control
- IR Transmission to Eliminate Possible Interference of Multi-Scale Application
- Built-in Indicator to show Signal is being Transmitted

Bluetooth 2.0 Supports: -

- aCrane Android App
- CT-10 Bluetooth Barcode Reader for Customer & Product Code Entries
- DP250 Bluetooth Ticket Printer
- Other Devices with Bluetooth 2.0 Communication

Bluetooth 4.0 Supports: -

- iCrane iOS App
- Other Devices with Bluetooth 4.0 Communication



Distributor Configurable Parameters

- 10 x Initial Zero Range
- 10 x Manual Zero Range
- 12 x Auto Zero Tracking Range
- Gravity Compensation



Versatility, Functionality and Accuracy are always Built-in

CS_a Advanced Wireless Crane Scale

Data Base Output Format Examples

Opr	Seq	Mode	Mac	MacGp	Date	Time	Name	PCode	Gross	Tare	Net	Total.W	Unit
22	1	0	2200	88	2017/11/3	10:53:54	Fidelity	CSa-2001	1001	0	1001	1001	kg
22	2	0	2200	88	2017/11/3	10:53:56	Fidelity	CSa-2001	1001	0	1001	2002	kg
22	3	0	2200	88	2017/11/3	10:54:06	Fidelity	CSa-2001	2003	0	2003	4005	kg
22	4	0	2200	88	2017/11/3	10:54:13	Fidelity	CSa-2001	501	0	501	4506	kg

Lab 3 Data Base Output Content Illustration for Crane and Animal Weighing

Opr	Seq	Mode	Mac	MacGp	Date	Time	Name	PCode	Tare	Peak	Unit
22		3	2200	88	2017/11/3	11:09:07	Fidelity	CSa-2001	501	1001	kg
22		3	2200	88	2017/11/3	11:09:25	Fidelity	CSa-2001	501	1001	kg
22		3	2200	88	2017/11/3	11:09:31	Fidelity	CSa-2001	0	501	kg
22		3	2200	88	2017/11/3	11:09:36	Fidelity	CSa-2001	501	1502	kg

Lab 3 Data Base Output Content Illustration for Peak Hold

Standard Printout Format Examples

Crane Weighing	
Time	10:48:26
Date	2017/11/3
Seq	001
Name	Fidelity
Pcode	CSa-2001
Net	1001kg
Tare	0kg
Gross	1001kg
Total	1001kg

Peak Hold	
Time	10:49:44
Date	2017/11/3
Name	Fidelity
Pcode	CSa-2001
Peak	1502kg

Animal Weighing	
Time	10:50:42
Date	2017/11/3
Seq	001
Name	Fidelity
Pcode	CSa-2001
Hold.W	1001kg
Total	1001kg

Lab 2 Output Content Illustration for Various Modes

Lab 4			
Name	Fidelity		
Pcode	CSa-2001		
Opr	22		
Mac	2200		
MacGp	88		
Date	2017/11/3		
Time	11:14:28		
	Seq	Gross	Net
	001	501	501 kg
	002	1001	1001 kg
	003	1001	1001 kg
	004	1502	1502 kg

	004	4005	kg
Max	1502	kg	
Min	501	kg	
Diff	1001	kg	
x	1001.3	kg	
Sd	408.7	kg	
Srel	40.8169	%	

Lab 5			
Name	Fidelity		
Pcode	CSa-2001		
Opr	22		
Mac	2200		
MacGp	88		
Date	2017/11/3		
	Seq	Time	Net
	001	11:18:26	501 kg
	002	11:18:35	1001 kg
	003	11:18:39	1502 kg
	004	11:18:45	2003 kg

	004	Total	5007 kg
Max	2003	kg	
Min	501	kg	
Diff	1502	kg	
x	1251.8	kg	
Sd	646.4	kg	
Srel	51.6376	%	

Max = Maximum Value
Min = Minimum Value
Diff = Differentiation (Max - Min)
x = Mean (Average) Value
Sd = Standard Deviation
Srel = Relative Standard Deviation

Lab 4 & Lab 5 Output Content Illustration for Crane and Animal Weighing

Versatility, Functionality and Accuracy are always Built-in

CS_a Advanced Wireless Crane Scale

Specifications

Model	Capacity			Readability (Standard)			Readability (High)		
	kg	lb	Newton	kg	lb	Newton	kg	lb	Newton
CSa-1T	1000	2204	9806	0.5	1	5	0.2	0.5	2
CSa-2T	2000	4408	19612	1	2	10	0.5	1	5
CSa-3T	3000	6614	29420	1	2	10	0.5	1	5
CSa-5T	5000	11024	49030	2	5	20	1	2	10
CSa-10T	10,000	22046	98060	5	10	50	2	5	20
CSa-15T**	15,000	33070	147.10K	10	20	0.1K	5	10	0.05K
Weight Units	kg, g, Newton								
Display	<ul style="list-style-type: none"> • 5 x Super Bright 30mm LED Display • Capacity Tracking Bar • • • Memory Accumulation, IR, Bluetooth & WIFI Data Transmission Indicators • Zero, Net, kg, lb and Newton Indicators 								
A/D Converter	24 bit Low-Noise Delta to Sigma ($\Delta-\Sigma$)								
Power Source	<ul style="list-style-type: none"> • Built-in Rechargeable Battery = 6V, 4AH, • External Battery Charger = DC 6.9V, 1A 								
Accessories	DC6.9V/1A Battery Charger, Second Rechargeable Battery and IR Remote Controller								
Tare Range	To Capacity by Subtraction								
Operation Environment	-10 ~ 40°C. Non-condensed. R.H. ≤ 85%								

In the interest of improvement, specifications may change prior to notice

** Not yet submitted for the 500% ultimate overload test

Options

- WIFI Module
- Free of Charge Bluetooth 2.0 Module (to replace the Built-in BT4.0 BLE module)
- WM-SP Wireless Communication Module for RF Transmission
- CT-10 Bluetooth Barcode Reader (Bluetooth 2.0 only)
- DPP250 Bluetooth Thermal Ticket Printer (Bluetooth 2.0 only)
- 3" or 5" Remote Display

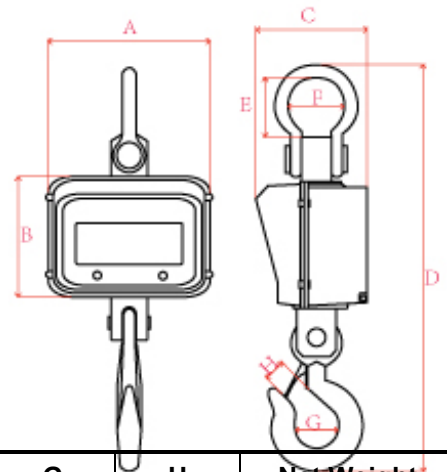

Dimensions & Weight

Model	A	B	C	D	E	F	G	H	Net Weight*
CSa-1T	255	190	205	580	70	67	46	35	13.5kg
CSa-2T	255	190	205	580	70	67	46	35	13.5kg
CSa-3T	255	190	205	580	70	67	46	35	13.5kg
CSa-5T	255	190	205	680	88	73	60	45	18.5kg
CSa-10T	255	190	205	780	114	92	71	59	30.0kg
CSa-15T	255	190	205	830	120	97	77	65	36.5kg

Dimensions Unit = mm



Fidelity Measurement Company Limited

www.fm.com.tw

info@fm.com.tw

REV.: CSa/26/05/06